

# Gasetm™ CR2000 FTIR Gas Analyzer



## Multicomponent FTIR Gas Analyzer

Gasetm In-lab Series includes quantitative multicomponent gas analyzers for laboratory research applications. The Gasetm CR2000 incorporates a Fourier transform infrared, FTIR spectrometer, a temperature controlled sample cell, and signal processing electronics. Liquid nitrogen cooled MCT detector has the highest performance available.

The Gasetm CR2000 is designed for speed and reliability. It is an ideal tool for example for motor exhaust measurements, catalyst research applications, pyrolysis research, or to measure any compounds in wet corrosive gas mixtures. The small volume of the sample cell provides short response times. The gold-coated sample cell can be heated up to 180 °C.

CR-models scanning and analysis speed can be configured according to customers need.

### General parameters

<b>Measuring principle:</b>	Fourier transform infrared, FTIR
<b>Performance:</b>	Simultaneous analysis of up to 50 gas compounds
<b>Response time, T<sub>90</sub>:</b>	Typically << 25 s, depending on the gas flow and measurement time
<b>Operating temperature:</b>	5 -30 °C, non-condensing
<b>Storage temperature:</b>	-20 – 60 °C, non-condensing
<b>Power supply:</b>	100-115 or 230 V / 50 -60 Hz
<b>Power consumption:</b>	300 W max, continuous 150 W

### Spectrometer

<b>Resolution:</b>	Recommended 8 cm <sup>-1</sup> or 4 cm <sup>-1</sup>
<b>Scan frequency:</b>	10 scans / s or faster
<b>Detector:</b>	Liquid N <sub>2</sub> cooled MCT
<b>Source:</b>	SiC, 1550 K
<b>Optics material:</b>	ZnSe (beamsplitter and windows)
<b>Wave number range:</b>	600 - 4200 cm <sup>-1</sup>

### Sample cell

<b>Structure:</b>	Multi-pass, fixed path length 2 m
<b>Standard material:</b>	100 % rhodium coated aluminium
<b>Mirrors:</b>	Fixed, protected gold coating
<b>Volume:</b>	0.22 liters
<b>Connectors:</b>	Inlet Swagelok 6 mm Outlet Swagelok 8 mm
<b>Gaskets:</b>	Viton® O-rings
<b>Temperature:</b>	180 °C, maximum
<b>Window material:</b>	ZnSe

### Measuring parameters

<b>Zero point calibration:</b>	24 hours, calibration with nitrogen (4.0 or higher N <sub>2</sub> recommended)
<b>Zero point drift:</b>	< 2 % of measuring range per zero point calibration interval

<b>Sensitivity drift:</b>	None
<b>Linearity deviation:</b>	< 2 % of measuring range
<b>Temperature drifts:</b>	< 2 % of measuring range per 10 K temperature change
<b>Pressure influence:</b>	1 % change of measuring value for 1 % sample pressure change. Ambient pressure changes measured and compensated

### Electrical connectors

<b>Digital interface:</b>	9-pole D-connector for RS-232 CR2000 is connected to an external computer via RS-232C cable. The external computer controls Gasmeter.
<b>Power connection:</b>	Standard plug CEE-22

### Gas inlet and outlet conditions

<b>Gas temperature:</b>	Non-condensing, the sample gas temperature should be the same as the sample cell temperature
<b>Flow rate:</b>	120 - 600 liters per hour
<b>Gas filtration:</b>	Filtration of particulates (2 µ) required
<b>Sample gas pressure:</b>	Ambient
<b>Sample pump:</b>	External, not included

### Electronics

<b>A/D converter:</b>	Dynamic range 95 dB
<b>Signal processor:</b>	32-bit floating point DSP 120 MFLOPS
<b>Computer:</b>	External, not included

### Analysis software (for external PC)

<b>Operating system:</b>	Windows XP
<b>Analysis software:</b>	Calcmeter for Windows

### Options

<b>Sample cell:</b>	Multi-pass, fixed path length 0.4
<b>Pressure measurement:</b>	Inside sample cell
<b>External PC:</b>	Gasmeter PC
<b>Sample cell gaskets:</b>	Teflon <sup>®</sup> coated Viton <sup>®</sup> or Kalrez <sup>®</sup>
<b>Enclosure:</b>	19" rack
<b>LN<sub>2</sub> detector:</b>	33 hours Dewar

### Enclosure

<b>Material:</b>	Aluminium
<b>Dimensions (mm):</b>	512 * 473 * 311
<b>Weight:</b>	22 kg
<b>CE label:</b>	According to EMI guideline 89/336/EC

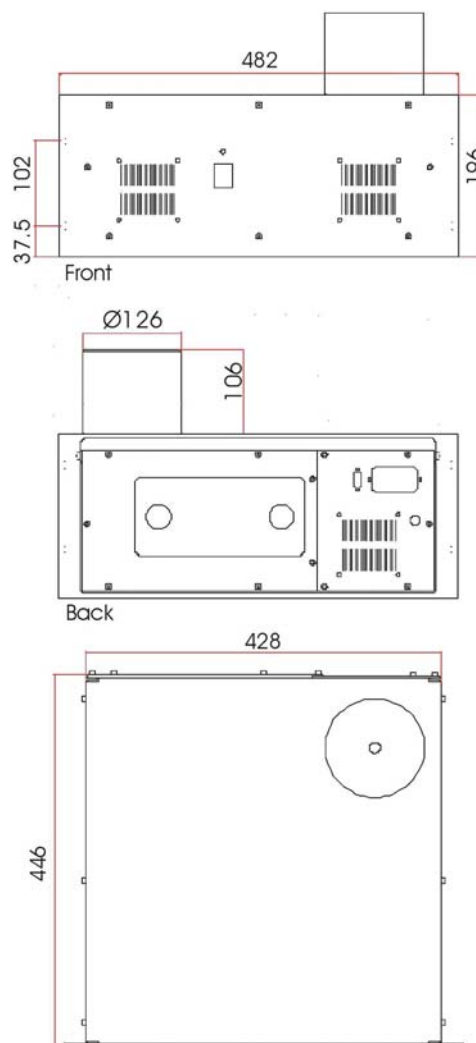

Gasmeter Technologies Oy shall not be liable for technical or editorial errors or omissions contained herein. The information in this document is provided "as is" without warranty of any kind and is subject to change without notice. Should you find any errors, we would appreciate if you notified us.